

 **SmartFork**<sup>®</sup>

The innovative forks for AGVs

Essential for more safety in logistics



## Sensor technology where it is needed: IN THE FORKS

Europe's leading fork manufacturer VETTER offers sophisticated solutions for equipping your AGV's with forks. With intelligent sensor technology, and the ability to easily adapt them to a wide range of requirements. **AGV ready!** Detailed and safe load detection and pick-up with the SmartFork<sup>®</sup> from VETTER.

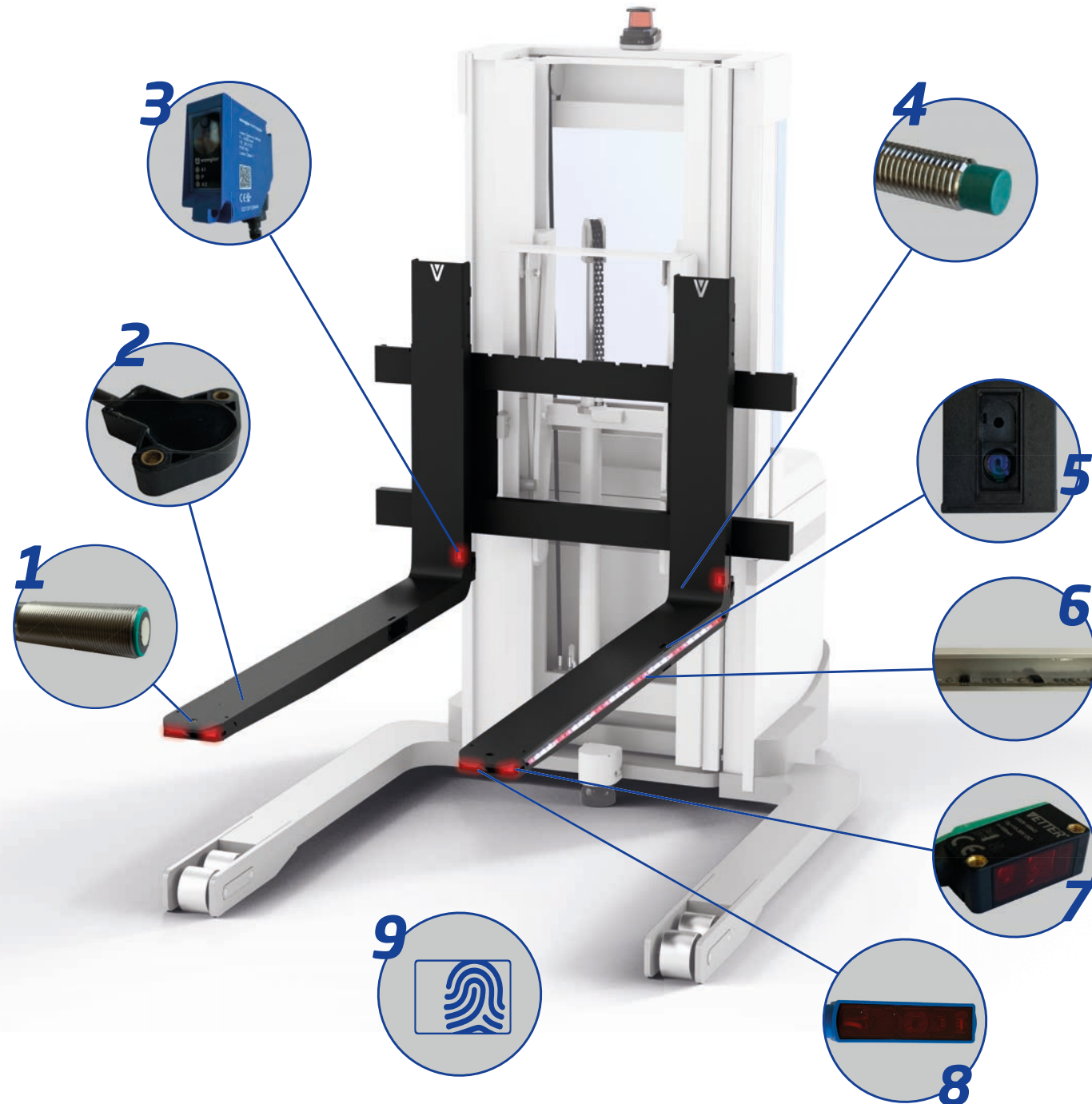

## Innovative sensor technology integrated into the forks

- 1 OBSTACLE DETECTION**  
Early detection of loads and interfering edges by means of ultrasound
- 2 TILT SENSOR**  
Detection of the fork tip deflection under load
- 3 LOAD CONTROL**  
Position monitoring of the fork load
- 4 INDUCTIVE LOAD STOP SENSOR**  
Precise monitoring of the load on the fork back
- 5 OCCUPANCY SENSOR WITH ENTRY DEPTH MEASUREMENT**  
Prevents fork tip from piercing load behind
- 6 LED ELEMENTS**  
Improved visibility of the forks. Indispensable where man and machine are working together
- 7 DISTANCE SENSOR**  
Early detection of load and interfering edges by means of optical distance sensors
- 8 PALLET BREAK SENSOR**  
Detection of obstacles in pallet pockets (e.g. broken boards, sagging load)
- 9 YOUR INDIVIDUAL SENSOR**

### COMING SOON:

Sensor for monitoring the load movement - reducing the risk of the AGV tipping over

## AGV ready! - From practice



Safe load pick-up thanks to distance sensors in the fork tip.



AGV sensor fork with obstacle detection in the tip and anti-slip coating.

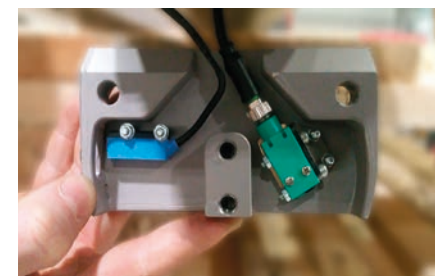

Integrated cable routing for power supply and data transmission in the fork.

- ✓ Sensors directly on the load
- ✓ Individual cable routing including tough and robust use
- ✓ Connectors made to measure
- ✓ Standardised communication interfaces via I/O link, CAN-open etc.



## Your all-round carefree package - from the idea to the ready-to-install solution!

### VETTER expertise

Our team of experts supports you from the initial idea to ready-to-install solutions! Benefit from the expertise of the market leader.

**Make your AGV the safest warehouse assistant.**

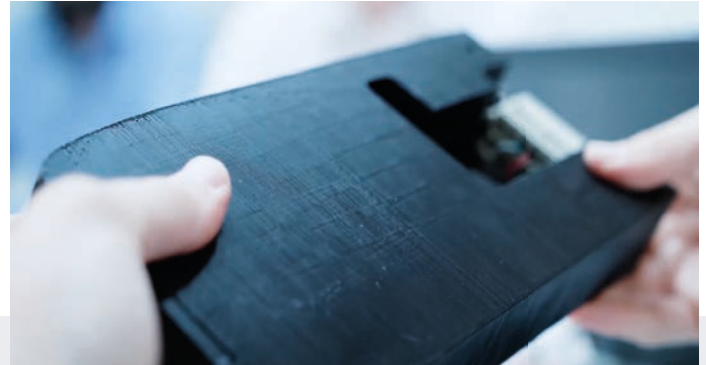

- ✔ **Project management** with free workshops to develop innovative sensor concepts according to your requirements
- ✔ **Industrial strength** for the toughest operating conditions and durability
- ✔ **Advice** on design and functionality
- ✔ **Individual solution** for your application
- ✔ **Certified according to ISO 2330** with strength verification as well as millimetre-accurate indication of tip deflection under load
- ✔ **Mechanical processing** for optimum installation of the sensor technology by VETTER
- ✔ **Standardised communication interfaces** such as I/O link, CANopen etc.
- ✔ **Plug&Play** thanks to ready-to-install solutions
- ✔ **Installation service** with pre-setting of sensor parameters including function tests
- ✔ **Manufacturer's warranty** with after-sales service on the complete solution supplied

The VETTER SmartFork<sup>®</sup> has inspired you to strive for an individual solution for your AGV? Get in touch with us!

**OLIVER LOTZ**  
+1 717 401 5225  
oliver.lotz@forks.com

